

# DURAPAC

## COMPACTION SYSTEMS

The Durapac CB1250 is a powerful and versatile static compactor, designed and manufactured to compact medium to high volumes of dry or mixed waste and recyclable materials. It is ideal for warehouses, factories, pack-houses, shopping centres, retail outlets, office blocks, catering operations and hospitals, etc.

The controls are simple, and contained within a locking, vandal-proof cabinet. When full, the container connected to the CB1250 is collected, emptied and returned by a roll-on-off vehicle.

Loading can be by hand, forklift tip skip, automatic bin lift for 240-1100 litre wheelie bins, chute, conveyor, air extraction system, from ground or dock level, using a choice of open or enclosed safety hoppers and interlocked doors, etc.

Full telemetry and remote access are standard which allow us to quickly help if you have a service problem and enables the machine to message your collection partner as it becomes full, saving transport costs and reducing your carbon footprint.

- Reduce waste disposal costs
- Improve site safety
- Save time, labour and space
- Cut Co2 emissions and environmental impact

CB1250 SPECIFICATION	DETAIL
Charge Box Volume	1.8m <sup>3</sup>
Motor Size (Kw)	7.5/11
Cycle Time (Secs)	45/60s
Power Supply	415V 3 Phase
Running Pressure (PSI)	1600
Penetration Into Container (mm)	400
Machine Weight (Kg)	3000
Clear Top Opening WxL (mm)	1500x1260
Ram Bore / Ram Stroke (mm)	125/1600
Compaction Force (Tonne)	26/38
Boost Pressure (PSI)	2200
Length (mm)	3500
Width (mm)	1950
Height (mm)	1400
Head Face Area (m <sup>2</sup> )	1.08

## Durapac CB1250 Static Compactor

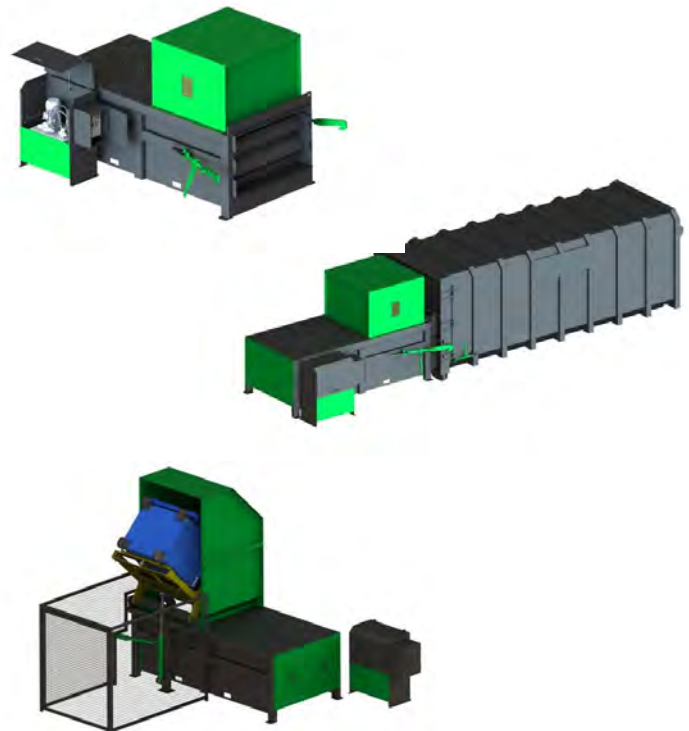

[www.compactandbale.com](http://www.compactandbale.com)  
[sales@compactandbale.com](mailto:sales@compactandbale.com)  
01732 85 22 44

